

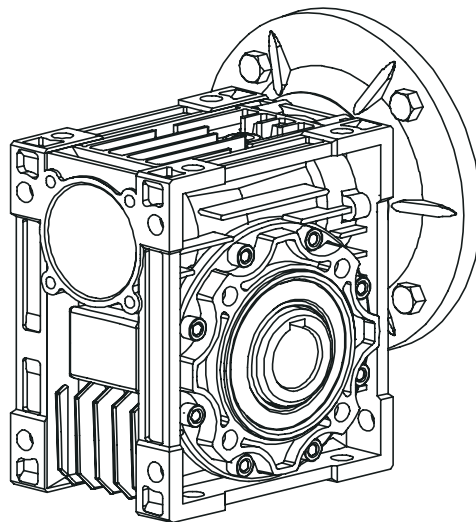

1.0 RIDUTTORI UNIVERSALI A VITE SENZA FINE WORM GEARBOXES SCHNECKENGETRIEBE

WI WMI

			Pag. Page Seite
1.2	Designazione	<i>Designation</i>	12
1.4	Lubrificazione	<i>Lubrication</i>	14
1.5	Carichi radiali e assiali	<i>Axial and overhung loads</i>	16
1.6	Prestazioni riduttori	<i>Gearboxes performances</i>	19
1.8	Dimensioni	<i>Dimensions</i>	113
1.9	Accessori braccio di reazione	<i>Accessories torque arm</i>	117
1.10	Accessori alberi lenti	<i>Accessories output shafts</i>	117
1.11	Cappellotto	<i>Cover</i>	118



WMI

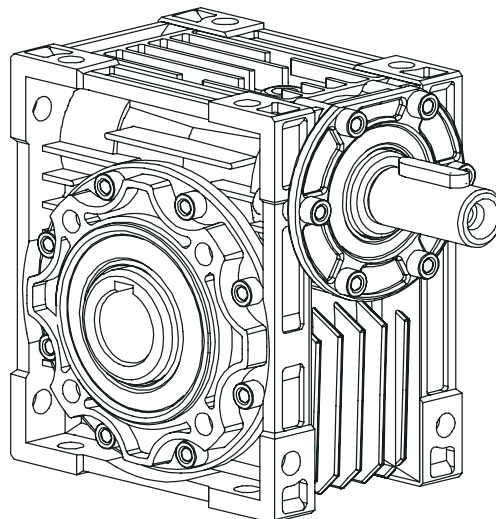

WI



1.2 Designazione

1.2 Designation

1.2 Bezeichnung

	Grandezza Size Größe	Versione Version Ausführung	ir	IEC	Tipo Type Typ	Grandezza Size Größe	Lunghezza Lenght Länge	[*1]	[*2]	[*3]								
WMI	25	-	vedi tabelle see tables siehe Tabellen	63 (B5)	T	56	A	-	B	ø19	-		Designazione Motori Designation Motors Bezeichnung Motoren CT18IGBD1 WMI 40 1/20 PAM 63 (B5)					
	30			63 (B14)										ø24 (standard)	WMI 40 1/20 T 56 A 4 B5			
	40														ø28		
	50			TA														
	63																WI 40 1/20
	75																
90	ML																
110		ø35															
130			ø38														
150				SIN													
WI																		

• [*1] Bisporgenza Vite:

Nessuna indicazione = vite senza bisporgenza;
B = vite con bisporgenza.

• [*1] Double Extended Input Shaft

No indications = input shaft without double extension;
B = double extended input shaft.

• [*1] Doppelseitige Schneckenwelle

Keine Angabe = Schnecken ohne doppeltes Wellenende
B = Schnecke mit doppeltem Wellenende

• [*2] Diametro albero:

Nessuna indicazione = diametro foro standard;
diametro foro opzionale = (vedi tabella).

• [*2] Shaft Diameter:

No indications = standard hole diameter;
optional hole diameter = (see table).

• [*2] Wellendurchmesser:

Keine Angabe = Standard-Bohrungsdurchmesser
Optionaler Bohrungsdurchmesser = (siehe Tabelle).

		Grandezza - Size - Größe									
WI - WMI		25	30	40	50	63	75	90	110	130	150
D H7	Standard	11	14	18	25	25	28	35	42	45	50

• [*3] Lato flangia uscita:

Nessuna indicazione = flangia uscita con montaggio destro (flange dal lato come indicato nelle figure del catalogo);
SIN = flange uscita con montaggio sinistro (flange dal lato opposto alle figure indicate a catalogo).

• [*8] Mounting position output side:

No indication (standard) = output flange on right side (like indicated in the figures);
SIN = output flange on left side (flanges on the opposite side like indicated in figures).

• [*8] Montageseite Abtriebsflansch:

Keine Angabe (Standard) = Abtriebsflansch rechts (wie in den Abbildungen dargestellt)
SIN = Abtriebsflansch links (gegenüber der Position in den Katalogabbildungen).



1.2 Designazione

1.2 Designation

1.2 Bezeichnung

ALTRE SPECIFICHE:

- posizione della morsetteria del motore se diversa da quella standard (1)

FURTHER SPECIFICATION:

- terminal board box position if different from standard (1)

WEITERE SPEZIFIKATIONEN:

- Stellung des Klemmenkastens des Motors, falls diese von der Standard- Ausführung abweicht (1)

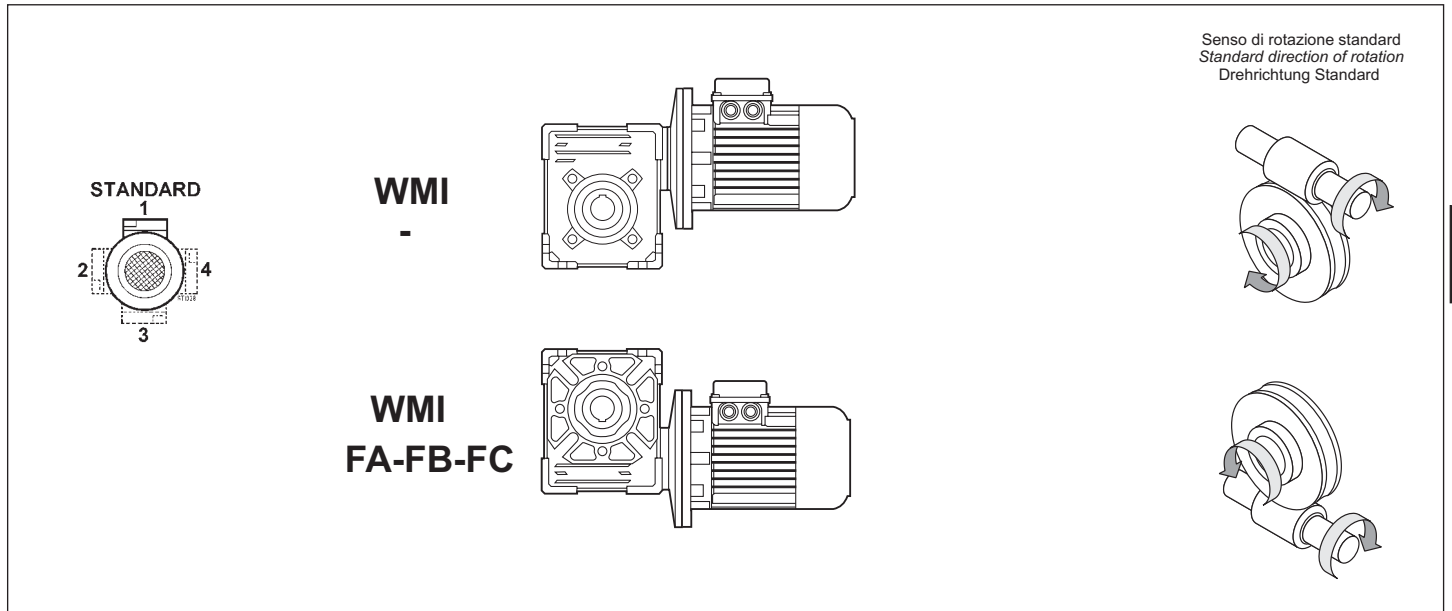
**ACCESSORI**

- alberi lenti
- braccio di reazione

ACCESSORIES

- output shafts
- Torque arm

ZUBEHÖR

- Abtriebswellen
- Drehmomentstütze



1.4 Lubrificazione

1.4 Lubrication

1.4 Schmierung



Lubrificazione riduttori
Gearboxes lubrication
Schmierung Getriebes

WI - WMI

Generalità

Si consiglia l'uso di oli a base sintetica. Vedere a tale proposito le indicazioni riportate nel capitolo A, paragrafo 1.6 e 1.2.. Nella tab. 2.2.1 sono riportati i quantitativi di olio necessari per il corretto funzionamento dei riduttori.

Prescrizioni in fase di ordine e stato di fornitura

I riduttori sono forniti completi di olio sintetico di viscosità ISO 320. Per questi riduttori **non è necessario** specificare la posizione di montaggio.

I riduttori delle grandezze 110, 130, 150 sono forniti predisposti per lubrificazione ad olio ma privi di lubrificante il quale potrà essere fornito a richiesta. Per questi riduttori **è necessario** specificare la posizione di montaggio.

General information

The use of synthetic oil is recommended. (see details in Chapter A, paragraph 1.6 and 1.2). Tab. 2.2.1 shows the quantities of oil required for correct worm gearbox performance.

Ordering phase requirements and state of supply

Worm gearboxes sizes 40, 50, 63, 75, and 85 come supplied with ISO 320 viscosity synthetic oil.

It is not necessary to specify mounting positions with these worm gearboxes.

Size 110, 130, 150 worm gearboxes require oil lubrication but are supplied without lubricant that can be requested separately. **It is necessary** to specify the mounting position for these worm gearboxes.

Allgemeines

Der Einsatz von synthetischem Öl wird empfohlen. (Siehe diesbezüglich die Hinweise im Kapitel A, abschnitt 1.6 und 1.2).

In der Tabelle Tab. 2.2.1 werden die erforderlichen Öfüllmengen für einen störungsfreien Betrieb der Getriebe aufgeführt.

Vorgaben für die bestellung und den lieferzustand

Die Getriebe in den Baugrößen werden komplett mit Synthetiköl mit einer Viskosität ISO 320 geliefert. Für diese Getriebe **muss** die Einbaulage **nicht** angegeben werden.

Die Getriebe in den Baugrößen 110, 130, 15080 sind bei der Lieferung für die Ölschmierung vorbereitet, enthalten jedoch kein Schmiermittel. Dieses kann auf Anfrage geliefert werden. Für diese Getriebe **muss** die Einbaulage verbindlich angegeben werden.

Posizioni di montaggio WI-WMI

Mounting positions WI-WMI

Montagepositionen WI-WMI

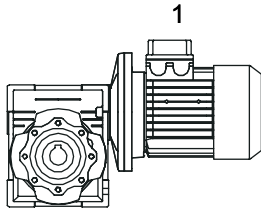
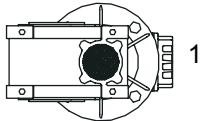
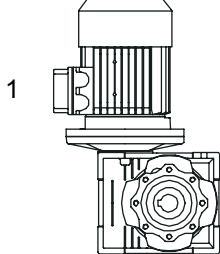
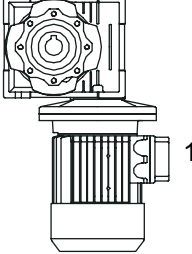
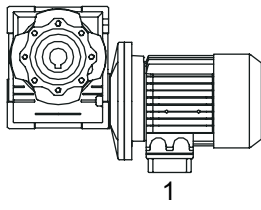
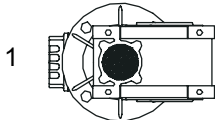
WI - WMI			
M1	M6	M3	M4
			
			



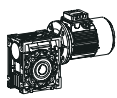

Tab. 2.2.1

WI-WMI	Quantità di lubrificante / Lubricant Quantity / Schmiermittelmenge (kg)						Stato di fornitura State of supply Lieferzustand	n°. tappi olio No. of plugs Anzahl Schrauben	Posizione di montaggio Mounting position Montageposition
	Posizioni di montaggio Mounting Positions Montagepositionen								
	M1	M2	M3	M4	M5	M6			
25	0.02						Riduttori forniti completi di lubrificante sintetico Gearboxes supplied with synthetic oil Getriebe werden mit synthetischem Öl geliefert	1	Non é necessaria It is not necessary Nicht Erforderlich
30	0.04							1	
40	0.08							1	
50	0.150							1	
63	0.300							1	
75	0.550							1	
90	1.000							1	
110	3.000	2.200	3.000	2.200	2.500		3	Necessaria Necessary Erforderlich	
130	4.500	3.300	4.500	3.300	3.500		3		
150	7.000	5.100	7.000	5.100	5.400		3		

(1) Quantità indicative; durante il riempimento attenersi alla spia di livello.

(1) Indicative quantities, check the oil sight glass during filling.

(1) Richtungsweisende Mengen, bei der Auffüllung auf das Füllstand-Kontrollfenster Bezug nehmen.

▽ Carico / Breather plug / Nachfüllen - Entlüftung

● Livello / Level plug / Pegel

▼ Scarico / Drain plug / Auslauf

A) Se in fase d'ordine la posizione di montaggio è omessa, il riduttore verrà fornito con i tappi predisposti per la posizione M1.

A) If the mounting position is not specified in the order, the worm gearbox supplied will have plugs pre-arranged for position M1.

A) Hinweis: Sollte in der Auftragsphase die Einbaulage nicht angegeben werden, wird das Getriebe mit Stopfen für die Einbaulage M1.

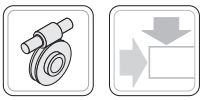

1.5 Carichi radiali e assiali

Il carico radiale sull'albero si calcola con la seguente formula:

$$Fr_e = \frac{2000 \cdot M \cdot fz}{D} \leq Fr1 \text{ o } Fr2$$

- Fre** (N)
Carico radiale risultante
- M** (Nm)
Momento torcente sull'albero
- D** (mm)
Diametro dell'elemento di trasmissione montato sull'albero
- Fr** (N)
Valore di carico radiale massimo ammesso (ved. tabelle relative)

- fz** = 1,1 pignone dentato
- 1,4 ruota per catena
- 1,7 puleggia a gola
- 2,5 puleggia piana

Quando il carico radiale risultante non è applicato sulla mezzzeria dell'albero occorre calcolare quello effettivo con la seguente formula:

$$Fr_e \leq \frac{Fr \cdot a}{(b + x)} \leq Fr1max \text{ o } Fr2max$$

a , b , x = valori riportati nelle tabelle

ALBERI IN USCITA

1.5 Axial and overhung loads

The radial load on the shaft is calculated with the following formula:

$$Fr_e = \frac{2000 \cdot M \cdot fz}{D} \leq Fr1 \text{ o } Fr2$$

- Fre** (N)
Resulting radial load
- M** (Nm)
Torque on the shaft
- D** (mm)
Diameter of the transmission member mounted on the shaft
- Fr** (N)
Value of the maximum admitted radial load (see relative tables)

- fz** = 1,1 gear pinion
- 1,4 chain wheel
- 1,7 v-pulley
- 2,5 flat pulley

When the resulting radial load is not applied on the centre line of the shaft it is necessary to calculate the effective load with the following formula:

$$Fr_e \leq \frac{Fr \cdot a}{(b + x)} \leq Fr1max \text{ o } Fr2max$$

a , b , x = values given in the tables

OUTPUT SHAFTS

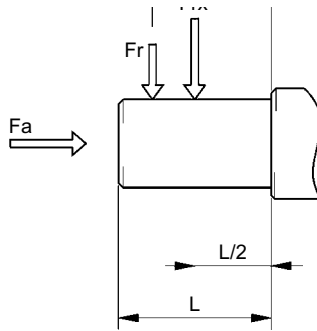

WI WMI	Fr ₂ (N)									
	25	30	40	50	63	75	90	110	130	150
a	50	65	84	101	120	131	162	176	188	215
b	38	50	64	76	95	101	122	136	148	174
Fr2 max	1350	1830	3490	4840	6270	7380	8180	12000	13500	18000

ALBERI IN ENTRATA

INPUT SHAFTS

1.5 Radiale und Axiale Belastungen

Die Querbelastung (Querkraft) auf der Welle wird durch nachstehende Formel berechnet:

$$Fr_e = \frac{2000 \cdot M \cdot fz}{D} \leq Fr1 \text{ o } Fr2$$

- Fre** (N)
resultierende Querkraft
- M** (Nm)
Wellendrehmoment
- D** (mm)
Durchmesser des an der Welle montierten Antriebselements
- Fr** (N)
max. zul. Querkraft (siehe entspr. Tafel)

- fz** = 1,1 Zahnrad
- 1,4 Rad für Kette
- 1,7 Flanschscheibe
- 2,5 Flachriemenscheibe

Wenn die Querkraft nicht auf die Mitte der Welle bezogen ist, ist die effektive Kraft durch nachstehende Formel zu berechnen:

$$Fr_e \leq \frac{Fr \cdot a}{(b + x)} \leq Fr1max \text{ o } Fr2max$$

a , b , x : siehe Tafeln

ABTRIEBSWELLEN

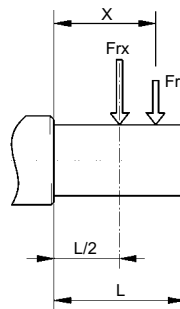

WI	Fr ₁ (N)								
	30	40	50	63	75	90	110	130	150
a	86	106	129	159	192	227	266	314	350
b	76	94.5	114	139	167	202	236	274	310
Fr1 max	210	350	490	700	980	1270	1700	2100	2800



1.5 Carichi radiali e assiali

1.5 Axial and overhung loads

1.5 Radiale und Axiale Belastungen

Valore di carico radiale massimo ammesso

Value of the maximum admitted radial load

Max. zul. Querkraft

WMI 25

ir	n ₁ = 2800		n ₁ = 1400		n ₁ = 900		n ₁ = 500	
	F _{r1} N	F _{r2} N	F _{r1} N	F _{r2} N	F _{r1} N	F _{r2} N	F _{r1} N	F _{r2} N
7.5				503				
10				553				
15				633				
20				697				
-				-				
30	-		-	798	-		-	
40				878				
50				946				
60				1006				
-				-				
-				-				

WI-WMI 30

ir	n ₁ = 2800		n ₁ = 1400		n ₁ = 900		n ₁ = 500	
	F _{r1} N	F _{r2} N	F _{r1} N	F _{r2} N	F _{r1} N	F _{r2} N	F _{r1} N	F _{r2} N
7.5	125	542	150	683	175	792	210	963
10	140	597	169	752	197	871	210	1060
15	140	683	169	861	197	997	210	1213
20	146	752	190	948	210	1098	210	1336
25	210	810	210	1021	210	1183	210	1439
30	210	861	210	1085	210	1257	210	1529
40	127	948	210	1194	210	1383	210	1683
50	128	1021	210	1286	210	1490	210	1813
60	126	1085	210	1367	210	1583	210	1830
80	130	1194	210	1504	210	1743	210	1830
100	-	-	-	-	-	-	-	-

WI-WMI 40

ir	n ₁ = 2800		n ₁ = 1400		n ₁ = 900		n ₁ = 500	
	F _{r1} N	F _{r2} N	F _{r1} N	F _{r2} N	F _{r1} N	F _{r2} N	F _{r1} N	F _{r2} N
7.5	233	1044	294	1315	319	1524	350	1853
10	272	1149	331	1447	350	1677	350	2040
15	291	1315	331	1657	350	1920	350	2335
20	204	1447	350	1824	350	2113	350	2570
25	236	1559	350	1964	350	2276	350	2769
30	350	1657	350	2087	350	2419	350	2942
40	350	1824	350	2298	350	2662	350	3238
50	350	1964	350	2475	350	2868	350	3488
60	350	2087	350	2630	350	3047	350	3490
80	350	2298	350	2895	350	3354	350	3490
100	350	2475	350	3118	350	3490	350	3490

WI-WMI 50

ir	n ₁ = 2800		n ₁ = 1400		n ₁ = 900		n ₁ = 500	
	F _{r1} N	F _{r2} N	F _{r1} N	F _{r2} N	F _{r1} N	F _{r2} N	F _{r1} N	F _{r2} N
7.5	324	1433	401	1805	448	2091	490	2544
10	378	1577	490	1987	490	2302	490	2800
15	399	1805	490	2274	490	2635	490	3205
20	417	1987	490	2503	490	2900	490	3528
25	482	2140	490	2696	490	3124	490	3800
30	490	2274	490	2865	490	3320	490	4038
40	490	2503	490	3153	490	3654	490	4445
50	490	2696	490	3397	490	3936	490	4788
60	490	2865	490	3610	490	4183	490	4840
80	490	3153	490	3973	490	4604	490	4840
100	490	3397	490	4280	490	4840	490	4840

WI-WMI 63

ir	n ₁ = 2800		n ₁ = 1400		n ₁ = 900		n ₁ = 500	
	F _{r1} N	F _{r2} N	F _{r1} N	F _{r2} N	F _{r1} N	F _{r2} N	F _{r1} N	F _{r2} N
7.5	1873	395	2359	500	2734	580	700	3325
10	2061	463	2597	571	3009	661	700	3660
15	2359	492	2973	615	3444	670	700	4190
20	2597	538	3272	667	3791	700	700	4611
25	2797	593	3524	700	4084	700	700	4967
30	2973	700	3745	700	4339	700	700	5279
40	3272	700	4122	700	4776	700	700	5810
50	3524	700	4440	700	5145	700	700	6259
60	3745	700	4719	700	5467	700	700	6270
80	4122	700	5193	700	6018	700	700	6270
100	4440	700	5595	700	6270	700	700	6270

WI-WMI 75

ir	n ₁ = 2800		n ₁ = 1400		n ₁ = 900		n ₁ = 500	
	F _{r1} N	F _{r2} N	F _{r1} N	F _{r2} N	F _{r1} N	F _{r2} N	F _{r1} N	F _{r2} N
7.5	560	2210	700	2785	810	3227	980	3925
10	703	2433	830	3065	975	3551	980	4320
15	727	2785	851	3509	980	4065	980	4945
20	872	3065	980	3862	980	4474	980	5443
25	980	3302	980	4160	980	4820	980	5863
30	980	3509	980	4421	980	5122	980	6231
40	980	3862	980	4865	980	5637	980	6858
50	980	4160	980	5241	980	6073	980	7380
60	980	4421	980	5569	980	6453	980	7380
80	980	4865	980	6130	980	7103	980	7380
100	980	5241	980	6603	980	7380	980	7380



1.5 Carichi radiali e assiali

1.5 Axial and overhung loads

1.5 Radiale und Axiale Belastungen

Valore di carico radiale massimo ammesso

Value of the maximum admitted radial load

Max. zul. Querkraft

WI-WMI 90

ir	n ₁ = 2800		n ₁ = 1400		n ₁ = 900		n ₁ = 500	
	F _{r1} N	F _{r2} N	F _{r1} N	F _{r2} N	F _{r1} N	F _{r2} N	F _{r1} N	F _{r2} N
7.5	715	2446	900	3081	1040	3570	1270	4343
10	900	2692	1082	3391	1270	3929	1270	4780
15	1034	3081	1257	3882	1270	4498	1270	5472
20	1120	3391	1270	4273	1270	4951	1270	6022
25	1270	3653	1270	4603	1270	5333	1270	6487
30	1270	3882	1270	4891	1270	5667	1270	6894
40	1270	4273	1270	5383	1270	6238	1270	7588
50	1270	4603	1270	5799	1270	6719	1270	8174
60	1270	4891	1270	6163	1270	7140	1270	8180
80	1270	5383	1270	6783	1270	7859	1270	8180
100	1270	5799	1270	7306	1270	8180	1270	8180

WI-WMI 110

ir	n ₁ = 2800		n ₁ = 1400		n ₁ = 900		n ₁ = 500	
	F _{r1} N	F _{r2} N	F _{r1} N	F _{r2} N	F _{r1} N	F _{r2} N	F _{r1} N	F _{r2} N
7.5	950	3090	1200	3893	1390	4511	1700	5488
10	1194	3401	1463	4285	1700	4965	1700	6040
15	1337	3893	1604	4905	1700	5684	1700	6914
20	1485	4285	1700	5399	1700	6256	1700	7610
25	1700	4616	1700	5816	1700	6739	1700	8198
30	1700	4905	1700	6181	1700	7161	1700	8711
40	1700	5399	1700	6803	1700	7882	1700	9588
50	1700	5816	1700	7328	1700	8491	1700	10320
60	1700	6181	1700	7787	1700	9023	1700	10320
80	1700	6803	1700	8571	1700	9931	1700	10320
100	1700	7328	1700	9232	1700	10320	1700	10320

WI-WMI 130

ir	n ₁ = 2800		n ₁ = 1400		n ₁ = 900		n ₁ = 500	
	F _{r1} N	F _{r2} N	F _{r1} N	F _{r2} N	F _{r1} N	F _{r2} N	F _{r1} N	F _{r2} N
7.5	1190	4042	1500	5092	1740	5901	2100	7178
10	1493	4449	1845	5605	2100	6494	2100	7900
15	1725	5092	2070	6416	2100	7434	2100	9043
20	1912	5605	2100	7062	2100	8182	2100	9953
25	2100	6038	2100	7607	2100	8814	2100	10722
30	2100	6416	2100	8084	2100	9366	2100	11394
40	2100	7062	2100	8897	2100	10309	2100	12540
50	2100	7607	2100	9584	2100	11105	2100	13500
60	2100	8084	2100	10185	2100	11801	2100	13500
80	2100	8897	2100	11210	2100	12989	2100	13500
100	2100	9584	2100	12076	2100	13500	2100	13500

WI-WMI 150

ir	n ₁ = 2800		n ₁ = 1400		n ₁ = 900		n ₁ = 500	
	F _{r1} N	F _{r2} N	F _{r1} N	F _{r2} N	F _{r1} N	F _{r2} N	F _{r1} N	F _{r2} N
7.5			1950	6962				
10			2267	7663				
15			2285	8771				
20			2674	9654				
25			2800	10400				
30			2800	11051				
40			2800	12163				
50			2800	13103				
60			2800	13924				
80			2800	15325				
100			2800	16508				



1.6 Prestazioni riduttori WI

1.6 WI Gearboxes performances

1.6 Leistungen der WI-Getriebe

WMI 25



0.7

ir	$n_1 = 2800 \text{ min}^{-1}$			$n_1 = 1400 \text{ min}^{-1}$			$n_1 = 900 \text{ min}^{-1}$			$n_1 = 500 \text{ min}^{-1}$			IEC
	n_2 min^{-1}	T_{2M} Nm	P kW	n_2 min^{-1}	T_{2M} Nm	P kW	n_2 min^{-1}	T_{2M} Nm	P kW	n_2 min^{-1}	T_{2M} Nm	P kW	
7.5				186.7	11	0.25							56
10				140	12	0.21							
15				93.3	12.3	0.15							
20				70	12.4	0.12							
-				-	-	-							
30				46.7	13.3	0.08							
40				35	12	0.08							
50				28	11	0.055							
60				23.3	10	0.04							
-				-	-	-							
-				-	-	-							

WI 30



1.2

ir	$n_1 = 2800 \text{ min}^{-1}$			$n_1 = 1400 \text{ min}^{-1}$			$n_1 = 900 \text{ min}^{-1}$			$n_1 = 500 \text{ min}^{-1}$			IEC
	n_2 min^{-1}	T_{2M} Nm	P kW	n_2 min^{-1}	T_{2M} Nm	P kW	n_2 min^{-1}	T_{2M} Nm	P kW	n_2 min^{-1}	T_{2M} Nm	P kW	
7.5	373.3	13	0.58	186.7	18	0.41	120	20	0.30	66.7	24	0.21	56-63
10	280	13	0.45	140	18	0.32	90	20	0.24	50	24	0.16	
15	186.7	13	0.31	93.3	18	0.23	60	20	0.17	33.3	24	0.12	
20	140	12	0.23	70	18	0.18	45	19	0.13	25	23	0.09	
25	112	15	0.25	56	20	0.18	36	23	0.14	20	29	0.10	
30	93.3	15	0.21	46.7	20	0.15	30	21	0.11	16.7	26	0.08	
40	70	14	0.16	35	18	0.11	22.5	21	0.09	12.5	24	0.06	
50	56	12	0.12	28	17	0.09	18	19	0.07	10	22	0.05	
60	46.7	12	0.10	23.3	16	0.08	15	18	0.06	8.3	20	0.04	
80	35	11	0.08	17.5	12	0.05	11.3	14	0.04	6.3	17	0.03	
-	-	-	-	-	-	-	-	-	-	-	-	-	

WI 40



2.3

ir	$n_1 = 2800 \text{ min}^{-1}$			$n_1 = 1400 \text{ min}^{-1}$			$n_1 = 900 \text{ min}^{-1}$			$n_1 = 500 \text{ min}^{-1}$			IEC
	n_2 min^{-1}	T_{2M} Nm	P kW	n_2 min^{-1}	T_{2M} Nm	P kW	n_2 min^{-1}	T_{2M} Nm	P kW	n_2 min^{-1}	T_{2M} Nm	P kW	
7.5	373.3	27	1.20	186.7	40	0.90	120	43	0.65	66.7	53	0.45	56-63-71
10	280	30	1.00	140	40	0.69	90	44	0.50	50	53	0.35	
15	186.7	31	0.72	93.3	39	0.48	60	45	0.36	33.3	56	0.26	
20	140	29	0.52	70	39	0.37	45	44	0.28	25	52	0.19	
25	112	28	0.42	56	38	0.30	36	44	0.23	20	49	0.15	
30	93.3	34	0.44	46.7	44	0.31	30	48	0.23	16.7	58	0.16	
40	70	31	0.32	35	41	0.23	22.5	44	0.17	12.5	53	0.12	
50	56	30	0.26	28	37	0.18	18	43	0.14	10	52	0.10	
60	46.7	27	0.21	23.3	35	0.15	15	38	0.11	8.3	46	0.08	
80	35	25	0.16	17.5	33	0.12	11.3	37	0.09	6.3	40	0.06	
100	28	22	0.12	14	29	0.09	9	33	0.07	5.0	38	0.05	

WI 50



3.5

ir	$n_1 = 2800 \text{ min}^{-1}$			$n_1 = 1400 \text{ min}^{-1}$			$n_1 = 900 \text{ min}^{-1}$			$n_1 = 500 \text{ min}^{-1}$			IEC
	n_2 min^{-1}	T_{2M} Nm	P kW	n_2 min^{-1}	T_{2M} Nm	P kW	n_2 min^{-1}	T_{2M} Nm	P kW	n_2 min^{-1}	T_{2M} Nm	P kW	
7.5	373.3	52	2.3	186.7	71	1.6	120	81	1.2	66.7	102	0.86	63-71-80
10	280	53	1.8	140	70	1.2	90	83	0.94	50	104	0.67	
15	186.7	57	1.3	93.3	73	0.88	60	84	0.67	33.3	102	0.47	
20	140	53	0.95	70	72	0.68	45	76	0.48	25	92	0.33	
25	112	51	0.75	56	69	0.54	36	76	0.39	20	94	0.28	
30	93.3	65	0.82	46.7	83	0.57	30	91	0.42	16.7	106	0.29	
40	70	59	0.59	35	77	0.42	22.5	83	0.31	12.5	99	0.22	
50	56	53	0.45	28	73	0.34	18	78	0.25	10	89	0.17	
60	46.7	50	0.37	23.3	68	0.28	15	74	0.21	8.3	82	0.14	
80	35	45	0.27	17.5	64	0.22	11.3	66	0.16	6.3	75	0.11	
100	28	40	0.21	14	52	0.16	9	56	0.12	5.0	69	0.09	



1.6 Prestazioni riduttori WI

1.6 WI Gearboxes performances

1.6 Leistungen der WI-Getriebe

WI 63



6.2

ir	$\Delta n_1 = 2800 \text{ min}^{-1}$			$n_1 = 1400 \text{ min}^{-1}$			$n_1 = 900 \text{ min}^{-1}$			$n_1 = 500 \text{ min}^{-1}$			IEC
	n_2 min ⁻¹	T_{2M} Nm	P kW	n_2 min ⁻¹	T_{2M} Nm	P kW	n_2 min ⁻¹	T_{2M} Nm	P kW	n_2 min ⁻¹	T_{2M} Nm	P kW	
7.5	373.3	92	4.0	186.7	126	2.8	120	151	2.2	66.7	180	1.5	71-80-90
10	280	96	3.2	140	129	2.2	90	152	1.7	50	188	1.2	
15	186.7	101	2.3	93.3	134	1.6	60	153	1.2	33.3	188	0.85	
20	140	97	1.7	70	131	1.2	45	149	0.91	25	178	0.63	
25	112	91	1.3	56	131	1.0	36	135	0.69	20	163	0.48	
30	93.3	120	1.5	46.7	164	1.1	30	176	0.79	16.7	204	0.54	
40	70	113	1.1	35	143	0.76	22.5	160	0.58	12.5	186	0.40	
50	56	102	0.83	28	133	0.60	18	146	0.45	10	174	0.32	
60	46.7	96	0.68	23.3	130	0.51	15	137	0.37	8.3	162	0.26	
80	35	86	0.49	17.5	119	0.39	11.3	127	0.29	6.3	138	0.19	
100	28	74	0.37	14	118	0.34	9	125	0.25	5.0	131	0.16	

WI 75



9.0

ir	$\Delta n_1 = 2800 \text{ min}^{-1}$			$n_1 = 1400 \text{ min}^{-1}$			$n_1 = 900 \text{ min}^{-1}$			$n_1 = 500 \text{ min}^{-1}$			IEC
	n_2 min ⁻¹	T_{2M} Nm	P kW	n_2 min ⁻¹	T_{2M} Nm	P kW	n_2 min ⁻¹	T_{2M} Nm	P kW	n_2 min ⁻¹	T_{2M} Nm	P kW	
7.5	373.3	128	5.6	186.7	185	4.1	120	212	3.1	66.7	253	2.1	71-80 90-100-112
10	280	141	4.7	140	190	3.2	90	223	2.5	50	266	1.7	
15	186.7	150	3.4	93.3	198	2.3	60	232	1.8	33.3	268	1.2	
20	140	160	2.8	70	210	1.9	45	232	1.4	25	281	0.98	
25	112	147	2.1	56	202	1.5	36	219	1.1	20	251	0.73	
30	93.3	170	2.1	46.7	233	1.5	30	249	1.1	16.7	299	0.77	
40	70	166	1.6	35	216	1.1	22.5	236	0.83	12.5	279	0.58	
50	56	149	1.2	28	206	0.89	18	217	0.65	10	248	0.44	
60	46.7	143	1.0	23.3	197	0.75	15	206	0.54	8.3	234	0.37	
80	35	130	0.72	17.5	187	0.58	11.3	200	0.43	6.3	220	0.29	
100	28	123	0.58	14	180	0.48	9	191	0.36	5.0	206	0.24	

WI 90



13.0

ir	$\Delta n_1 = 2800 \text{ min}^{-1}$			$n_1 = 1400 \text{ min}^{-1}$			$n_1 = 900 \text{ min}^{-1}$			$n_1 = 500 \text{ min}^{-1}$			IEC
	n_2 min ⁻¹	T_{2M} Nm	P kW	n_2 min ⁻¹	T_{2M} Nm	P kW	n_2 min ⁻¹	T_{2M} Nm	P kW	n_2 min ⁻¹	T_{2M} Nm	P kW	
7.5	373.3	207	8.9	186.7	287	6.3	120	336	4.8	66.7	406	3.3	80-90 110-112
10	280	236	7.7	140	306	5.1	90	365	4.0	50	433	2.7	
15	186.7	270	6.0	93.3	357	4.1	60	410	3.1	33.3	488	2.1	
20	140	258	4.4	70	351	3.1	45	395	2.3	25	477	1.6	
25	112	246	3.4	56	332	2.4	36	372	1.8	20	430	1.2	
30	93.3	311	3.7	46.7	415	2.6	30	454	1.9	16.7	568	1.4	
40	70	280	2.6	35	363	1.8	22.5	422	1.4	12.5	486	0.95	
50	56	263	2.0	28	339	1.4	18	391	1.1	10	451	0.75	
60	46.7	242	1.6	23.3	307	1.1	15	350	0.86	8.3	407	0.59	
80	35	229	1.2	17.5	285	0.83	11.3	314	0.63	6.3	368	0.45	
100	28	203	0.9	14	270	0.67	9	281	0.49	5.0	328	0.35	

WI 110



35.0

ir	$\Delta n_1 = 2800 \text{ min}^{-1}$			$n_1 = 1400 \text{ min}^{-1}$			$n_1 = 900 \text{ min}^{-1}$			$n_1 = 500 \text{ min}^{-1}$			IEC
	n_2 min ⁻¹	T_{2M} Nm	P kW	n_2 min ⁻¹	T_{2M} Nm	P kW	n_2 min ⁻¹	T_{2M} Nm	P kW	n_2 min ⁻¹	T_{2M} Nm	P kW	
7.5	373.3	386	16.6	186.7	546	12	120	644	9.2	66.7	788	6.4	80-90 100-112-132
10	280	433	14.1	140	588	9.8	90	702	7.6	50	844	5.2	
15	186.7	482	10.7	93.3	660	7.5	60	749	5.6	33.3	906	3.9	
20	140	475	8.0	70	649	5.6	45	722	4.1	25	856	2.8	
25	112	499	6.8	56	665	4.7	36	752	3.5	20	894	2.4	
30	93.3	552	6.5	46.7	727	4.5	30	847	3.5	16.7	988	2.4	
40	70	519	4.7	35	693	3.3	22.5	785	2.5	12.5	909	1.7	
50	56	498	3.7	28	656	2.6	18	753	2.0	10	882	1.4	
60	46.7	472	3.0	23.3	620	2.1	15	693	1.6	8.3	810	1.1	
80	35	398	2.0	17.5	512	1.4	11.3	586	1.1	6.3	668	0.76	
100	28	382	1.6	14	473	1.1	9	526	0.84	5.0	609	0.59	



WI 130

Kg 48.0

ir	⚠ $n_1 = 2800 \text{ min}^{-1}$			$n_1 = 1400 \text{ min}^{-1}$			$n_1 = 900 \text{ min}^{-1}$			$n_1 = 500 \text{ min}^{-1}$			IEC
	n_2 min^{-1}	T_{2M} Nm	P kW	n_2 min^{-1}	T_{2M} Nm	P kW	n_2 min^{-1}	T_{2M} Nm	P kW	n_2 min^{-1}	T_{2M} Nm	P kW	
7.5	373.3	514	22.1	186.7	741	16.1	120	871	12.3	66.7	1071	8.6	90 100-112-132
10	280	574	18.7	140	820	13.5	90	951	10.3	50	1153	7.1	
15	186.7	669	14.7	93.3	917	10.3	60	1055	7.8	33.3	1293	5.5	
20	140	660	11	70	905	7.8	45	1022	5.8	25	1222	4.0	
25	112	660	9.0	56	931	6.5	36	1031	4.8	20	1192	3.2	
30	93.3	774	9.0	46.7	1047	6.4	30	1152	4.7	16.7	1378	3.3	
40	70	727	6.5	35	1043	4.9	22.5	1099	3.5	12.5	1284	2.4	
50	56	696	5.1	28	972	3.8	18	1017	2.7	10	1216	1.9	
60	46.7	638	4.0	23.3	928	3.1	15	923	2.1	8.3	1105	1.5	
80	35	606	3.0	17.5	853	2.3	11.3	852	1.6	6.3	967	1.1	
100	28	525	2.2	14	742	1.7	9	751	1.2	5.0	877	0.85	

WI 150

Kg 84.0

ir	⚠ $n_1 = 2800 \text{ min}^{-1}$			$n_1 = 1400 \text{ min}^{-1}$			$n_1 = 900 \text{ min}^{-1}$			$n_1 = 500 \text{ min}^{-1}$			IEC
	n_2 min^{-1}	T_{2M} Nm	P kW	n_2 min^{-1}	T_{2M} Nm	P kW	n_2 min^{-1}	T_{2M} Nm	P kW	n_2 min^{-1}	T_{2M} Nm	P kW	
7.5				186.7	1200	25.5							100-112 132-160
10				140	1240	19.5							
15				93.3	1250	13.5							
20				70	1300	10.5							
25				56	1200	8.8							
30				46.7	1200	7.4							
40				35	1550	7.4							
50				28	1400	5.5							
60				23.3	1260	4.4							
80				17.5	1150	3.2							
100				14	1000	2.4							

⚠ ATTENZIONE!

Per situazioni con velocità di ingresso particolari attenersi alla tabella sotto riportata che evidenzia situazioni critiche per ogni riduttore (Vedere paragrafo

⚠ WARNING!

If in presence of non standard input speed please attain to the chart below considering extreme usage conditions for each gearbox (Look at chapter 1.2-A).

⚠ ACHTUNG!

Mit unstandardisierte Antriebsgeschwindigkeit bitte auf folgende Liste Bezug nehmen in Betrachtung der schwierigen Arbeitsbedingungen fuer jede

	UI - RI - WI													
	25	28	30	40	50	63	70	75	85	90	110	130	150	180
$1500 < n_1 < 3000$	OK	OK	OK	OK	OK									
$n_1 > 3000$	Contattare il ns. servizio tecnico Contact our technical dept Wenden Sie sich an unseren technischen Service													

I pesi riportati sono indicativi e possono variare in funzione della versione del riduttore.

Listed weights are for reference only and can vary according to the gearbox version.

Die angegebenen Gewichte sind Richtwerte und können je nach Getriebeversion etwas variieren.

N.B. Per i riduttori evidenziati dal doppio bordo nella colonna delle potenze è necessario verificare lo scambio termico del riduttore (come nel par. 1.7-A). Per maggiori informazioni contattare l'ufficio

NOTE. Please pay attention to the frame around the input power value: for this gearboxes it's important to check the thermal capacity (comp. chapter 1.7-A). For details please contact our technical

HINWEIS. Sind in den Tabellen Nennleistungen eingerahmt, so ist die thermische Leistungsgrenze der Getriebe zu beachten (s. S. 1.7-A). Für weitere Informationen wenden Sie sich



Possibili accoppiamenti con motori IEC
Possible couplings with IEC motors
Mögliche Verbindungen mit IEC-Motoren

WMI

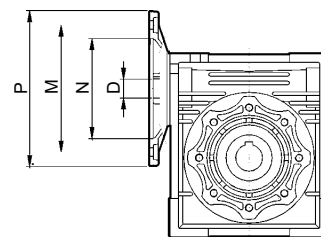

	IEC	N	M	P	ir										
					7.5	10	15	20	25	30	40	50	60	80	100
					D										
WMI 25	56 B14	50	65	80	∅ 9	∅ 9	∅ 9	∅ 9	-	∅ 9	∅ 9	∅ 9	∅ 9	-	-
WMI 30	63 B5	95	115	140	∅ 11	∅ 11	∅ 11	∅ 11	∅ 11	∅ 11	∅ 11	∅ 11	-	-	-
	63 B14	60	75	90	∅ 11	∅ 11	∅ 11	∅ 11	∅ 11	∅ 11	∅ 11	∅ 11	-	-	-
	56 B5	80	100	120	∅ 9	∅ 9	∅ 9	∅ 9	∅ 9	∅ 9	∅ 9	∅ 9	∅ 9	∅ 9	-
	56 B14	50	65	80	∅ 9	∅ 9	∅ 9	∅ 9	∅ 9	∅ 9	∅ 9	∅ 9	∅ 9	∅ 9	-
WMI 40	71 B5	110	130	160	∅ 14	∅ 14	∅ 14	∅ 14	∅ 14	∅ 14	∅ 14	-	-	-	-
	71 B14	70	85	105	∅ 14	∅ 14	∅ 14	∅ 14	∅ 14	∅ 14	∅ 14	-	-	-	-
	63 B5	95	115	140	∅ 11	∅ 11	∅ 11	∅ 11	∅ 11	∅ 11	∅ 11	∅ 11	∅ 11	∅ 11	∅ 11
	63 B14	60	75	90	∅ 11	∅ 11	∅ 11	∅ 11	∅ 11	∅ 11	∅ 11	∅ 11	∅ 11	∅ 11	∅ 11
	56 B5	80	100	120	-	-	-	-	-	-	-	∅ 9	∅ 9	∅ 9	∅ 9
WMI 50	80 B5	130	165	200	∅ 19	∅ 19	∅ 19	∅ 19	∅ 19	∅ 19	-	-	-	-	-
	80 B14	80	100	120	∅ 19	∅ 19	∅ 19	∅ 19	∅ 19	∅ 19	-	-	-	-	-
	71 B5	110	130	160	∅ 14	∅ 14	∅ 14	∅ 14	∅ 14	∅ 14	∅ 14	∅ 14	∅ 14	∅ 14	-
	71 B14	70	85	105	∅ 14	∅ 14	∅ 14	∅ 14	∅ 14	∅ 14	∅ 14	∅ 14	∅ 14	∅ 14	-
	63 B5	95	115	140	-	-	-	-	-	-	∅ 11	∅ 11	∅ 11	∅ 11	∅ 11
WMI 63	90 B5	130	165	200	∅ 24	∅ 24	∅ 24	∅ 24	∅ 24	∅ 24	-	-	-	-	-
	90 B14	95	115	140	∅ 24	∅ 24	∅ 24	∅ 24	∅ 24	∅ 24	∅ 24	∅ 24	∅ 24	∅ 24	-
	80 B5	130	165	200	∅ 19	∅ 19	∅ 19	∅ 19	∅ 19	∅ 19	∅ 19	∅ 19	∅ 19	∅ 19	-
	80 B14	80	100	120	∅ 19	∅ 19	∅ 19	∅ 19	∅ 19	∅ 19	∅ 19	∅ 19	∅ 19	∅ 19	-
	71 B5	110	130	160	-	-	-	-	-	-	∅ 14	∅ 14	∅ 14	∅ 14	∅ 14
	71 B14	70	85	105	-	-	-	-	-	-	∅ 14	∅ 14	∅ 14	∅ 14	∅ 14
WMI 75	100/112 B5	180	215	250	∅ 28	∅ 28	∅ 28	-	-	-	-	-	-	-	-
	100/112 B14	110	130	160	∅ 28	∅ 28	∅ 28	-	-	-	-	-	-	-	-
	90 B5	130	165	200	∅ 24	∅ 24	∅ 24	∅ 24	∅ 24	∅ 24	∅ 24	-	-	-	-
	90 B14	95	115	140	∅ 24	∅ 24	∅ 24	∅ 24	∅ 24	∅ 24	∅ 24	-	-	-	-
	80 B5	130	165	200	-	-	-	∅ 19	∅ 19	∅ 19	∅ 19	∅ 19	∅ 19	∅ 19	∅ 19
	80 B14	80	100	120	-	-	-	∅ 19	∅ 19	∅ 19	∅ 19	∅ 19	∅ 19	∅ 19	∅ 19
	71 B5	110	130	160	-	-	-	-	-	-	-	∅ 14	∅ 14	∅ 14	∅ 14
WMI 90	100/112 B5	180	215	250	∅ 28	∅ 28	∅ 28	∅ 28	∅ 28	∅ 28	-	-	-	-	-
	100/112 B14	110	130	160	∅ 28	∅ 28	∅ 28	∅ 28	∅ 28	∅ 28	-	-	-	-	-
	90 B5	130	165	200	∅ 24	∅ 24	∅ 24	∅ 24	∅ 24	∅ 24	∅ 24	∅ 24	∅ 24	-	-
	90 B14	95	115	140	∅ 24	∅ 24	∅ 24	∅ 24	∅ 24	∅ 24	∅ 24	∅ 24	∅ 24	-	-
	80 B5	130	165	200	-	-	-	-	-	-	∅ 19	∅ 19	∅ 19	∅ 19	∅ 19
	80 B14	80	100	120	-	-	-	-	-	-	∅ 19	∅ 19	∅ 19	∅ 19	∅ 19
WMI 110	132 B5	230	265	300	∅ 38	∅ 38	∅ 38	∅ 38	-	-	-	-	-	-	-
	100/112 B5	180	215	250	∅ 28	∅ 28	∅ 28	∅ 28	∅ 28	∅ 28	∅ 28	∅ 28	∅ 28	∅ 28	-
	90 B5	130	165	200	-	-	-	-	∅ 24	∅ 24	∅ 24	∅ 24	∅ 24	∅ 24	∅ 24
	80 B5	130	165	200	-	-	-	-	-	-	-	-	-	∅ 19	∅ 19
WMI 130	132 B5	230	265	300	∅ 38	∅ 38	∅ 38	∅ 38	∅ 38	∅ 38	∅ 38	-	-	-	-
	100/112 B5	180	215	250	-	-	-	-	∅ 28	∅ 28	∅ 28	∅ 28	∅ 28	∅ 28	∅ 28
	90 B5	130	165	200	-	-	-	-	-	-	-	-	-	∅ 24	∅ 24
WMI 150	160 B5	250	300	350	∅ 42	∅ 42	∅ 42	∅ 42	-	-	-	-	-	-	-
	132 B5	230	265	300	-	-	-	∅ 38	∅ 38	∅ 38	∅ 38	∅ 38	-	-	-
	100/112 B5	180	215	250	-	-	-	-	-	-	-	∅ 28	∅ 28	∅ 28	∅ 28



Dimensioni riduttori
Gearboxes dimensions
Abmessungen Getriebes

WI - WMI

25

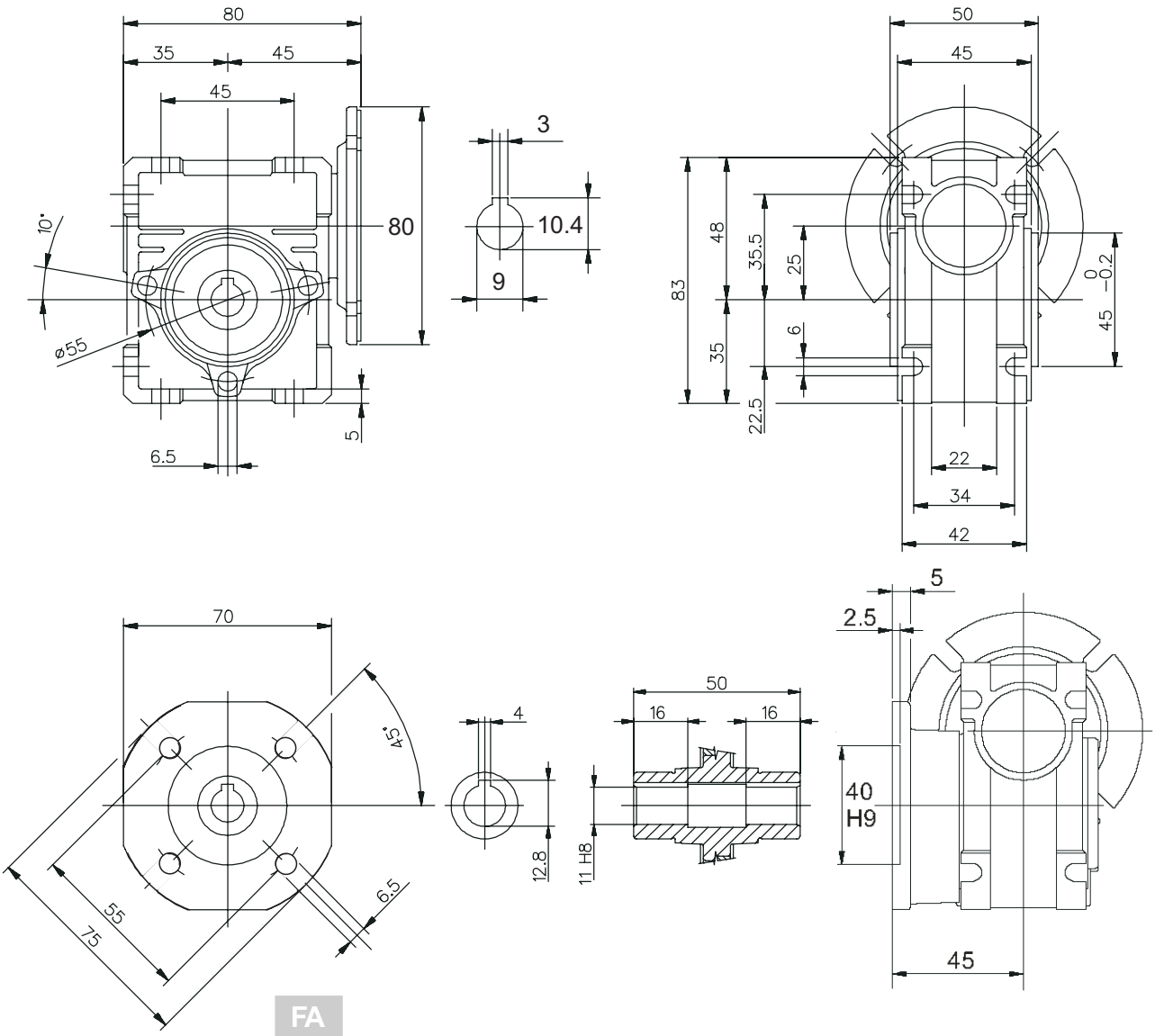



Dimensioni riduttori
Gearboxes dimensions
Abmessungen Getriebes

WI - WMI

30-40-50-63-75-110-130

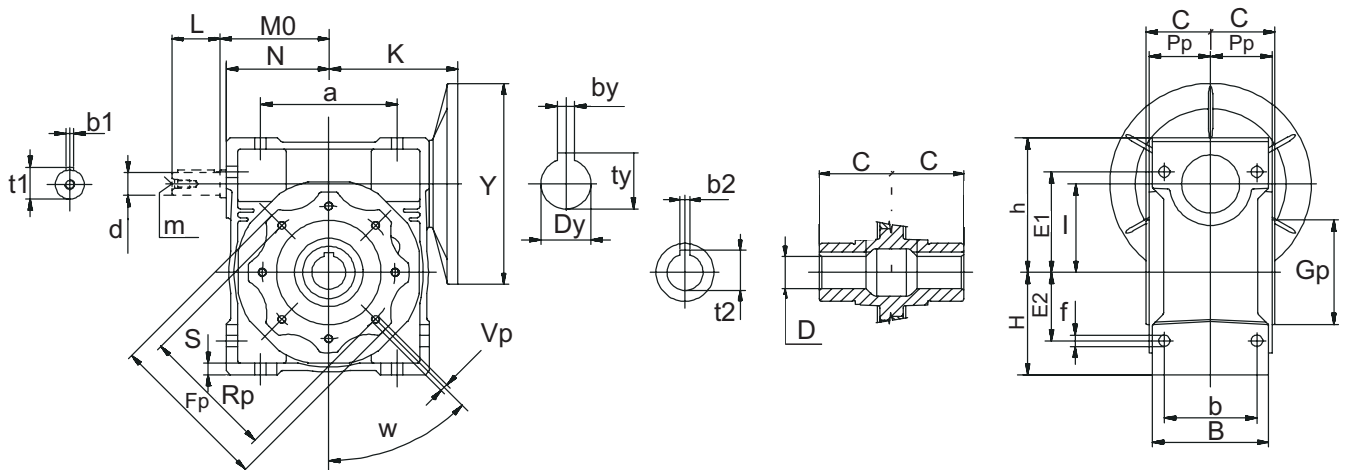

- FA
- FB
- FC

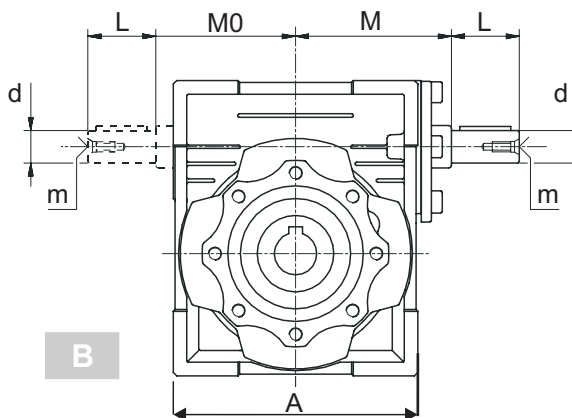
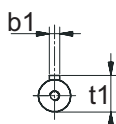
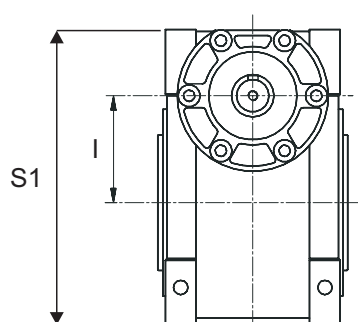
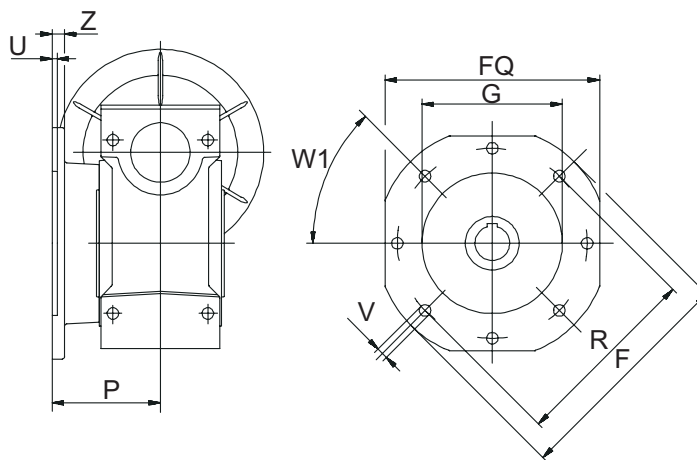



1.8 Dimensioni

1.8 Dimensions

1.8 Abmessungen

WI WMI	A	a	B	b	C	D H7	d j6	E1	E2	f	h	H	I	L	M	M0	m	N	S	S1
30	80	54	56	44	31,5	14	9	44	27	6,5	57	40	30	20	51	45	-	40	5,5	97
40	100	70	71	60	39	18	11	55	35	6,5	71,5	50	40	23	60	53	-	50	6,5	121,5
50	120	80	85	70	46	25	14	64	40	8,5	84	60	50	30	74	64	M6	60	7	144
63	144	100	103	85	56	25	19	80	50	8,5	102	72	63	40	90	75	M6	72	8	174
75	172	120	112	90	60	28	24	93	60	11	119	86	75	50	105	90	M8	86	10	205
90	208	140	130	100	70	35	24	102	70	13	135	103	90	50	125	108	M8	103	11	238
110	252,5	170	144	115	77,5	42	28	125	85	14	167,5	127,50	110	60	142	135	M10	127,50	14	295
130	292,5	200	155	120	85	45	30	140	100	16	187,5	147,50	130	80	162	155	M10	147,50	15	335
150	340	240	185	145	100	50	35	180	120	18	230	170,00	150	80	192	175	M12	170,00	18	400

WI WMI	Fp	Gp (h8)	Pp	Rp	Up	Vp	W	b2	t2	b1	t1
30	75	55	29	65		M6X11(n,4)	0	5	16,3	3	10,2
40	87	60	36,5	75		M6X8(n,4)	45	6(6)	20.8(21.8)	4	12,5
50	100	70	43,5	85		M8X10(n,4)	45	8(8)	28.3(27.3)	5	16,0
63	110	80	53	95		M8X14(n,8)	45	8(8)	28.3(31.3)	6	21,5
75	140	95	57	115		M8X14(n,8)	45	8(10)	31.3(38.3)	8	27,0
90	160	110	67	130		M10X18(n,8)	45	10(10)	38.3(41.3)	8	27,0
110	200	130	74	165		M10X18(n,8)	45	12	45,3	8	31,0
130	250	180	81	215		M12X21(n,8)	45	14	48,8	8	33,0
150	250	180	96	215		M12X21(n,8)	45	14	53,8	10	38,0

WI WMI	F	Fq	G (H8)	P	R	U	V	Z	W1	
30	FA	80	70	50	54,5	68	4	6.5(n,4)	6	45
40	FA	110	95	60	67	87	4	9(n,4)	7	45
	FC	140	-	95	76,5	115	5	9.5(n,4)	9	45
50	FB	110	95	60	97	87	4	9(n,4)	7	45
	FA	125	110	70	90	90	5	11(n,4)	9	45
63	FC	160	-	110	87,5	130	5	9.5(n,4)	10	45
	FB	125	110	70	120	90	5	11(n,4)	9	45
75	FA	180	142	115	82	150	6	11(n,4)	10	45
	FC	200	-	130	99	165	5	11(n,4)	11	45
90	FB	180	142	115	112	150	6	11(n,4)	10	45
	FA	200	170	130	111	165	6	14(n,4)	13	45
110	FA	210	200	152	111	175	6	14(n,4)	13	45
130	FA	280	260	170	131	230	6	14(n,4)	15	45
150	FA	320	290	180	140	256	6	16(n,4)	15	22.50
150	FA	320	290	180	155	255	6	16(n,4)	15	22.50

WM I	30		40		50		63		75		90		110		130		150	
	Y	K	Y	K	Y	K	Y	K	Y	K	Y	K	Y	K	Y	K	Y	K
B5	120	55	120	70														
	140	55	140	70	140	80												
			160	70	160	80	160	95	160	112,5								
					200	80	200	95	200	112,5	200	129,5	200	160	200	180		
									250	112,5	250	129,5	250	160	250	180	250	210
													300	160	300	180	300	210
B14	80	55																
	90	55	90	70														
			105	70	105	80	105	95										
					120	80	120	95	120	112,5	120	129,5						
							140	95	140	112,5	140	129,5						
								160	112,5	160	129,5							



1.8 Dimensioni

1.8 Dimensions

1.8 Abmessungen

PAM B5 - Dimensioni

PAM B5 -Dimensions

PAM B5 - Abmessungen

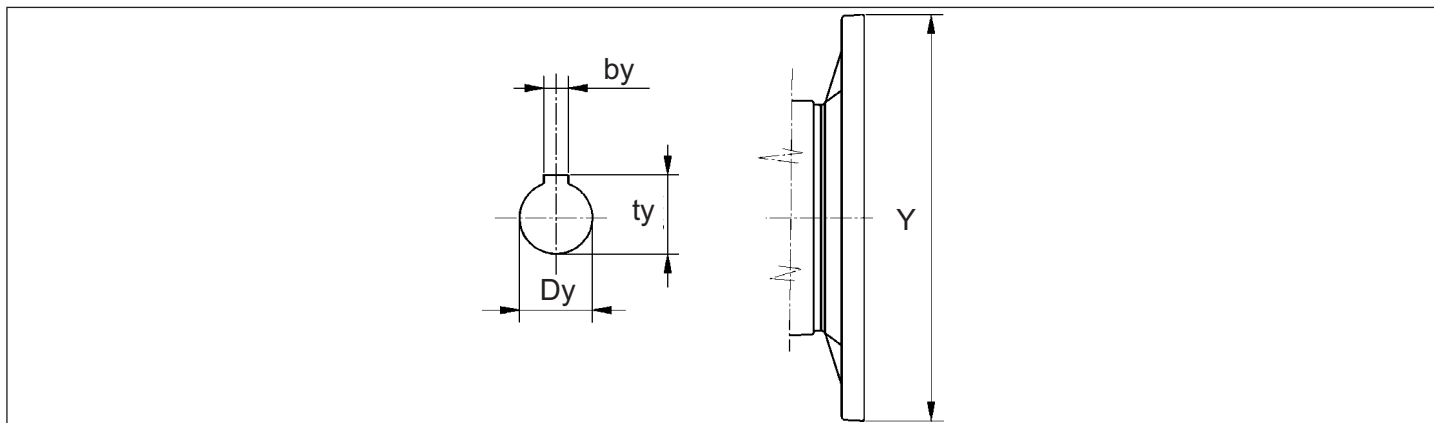

WMI	IEC										
B5	56	63	71	80	90	100	112	132	160	180	200
Y	120	140	160	200	200	250	250	300	350	350	400
Dy	9	11	14	19	24	28	28	38	42	48	55
by	3	4	5	6	8	8	8	10	12	14	16
ty	10.4	12.8	16.3	21.8	27.3	31.3	31.3	41.3*	45.3	51.8	59.3

PAM B14 - Dimensioni

PAM B14 -Dimensions

PAM B14 - Abmessungen

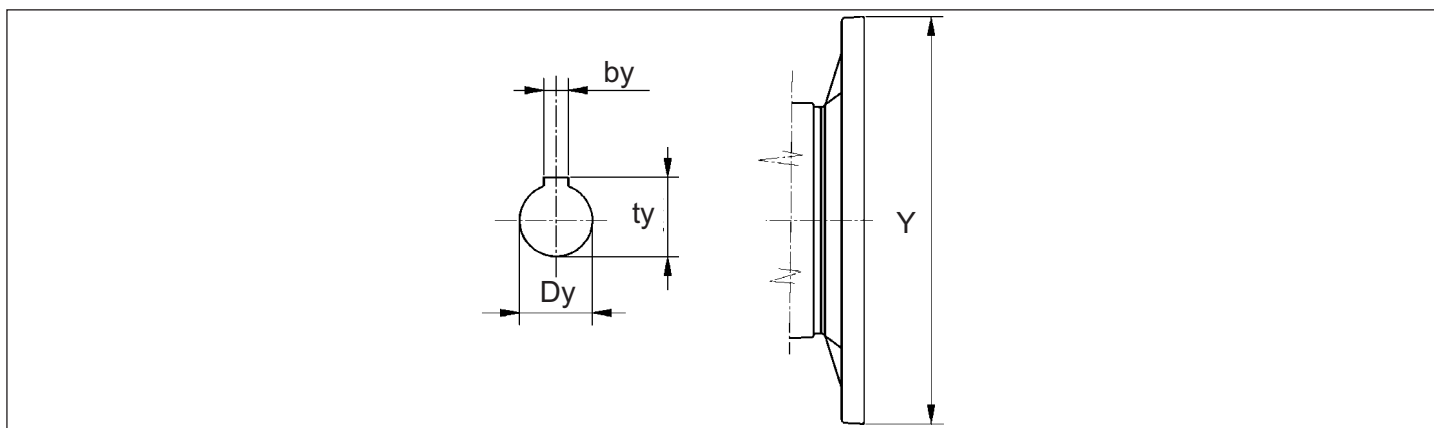

WMI	IEC								
B5	56	63	71	80	90	100	112	132	160
Y	80	90	105	120	140	160	160	200	200
Dy	9	11	14	19	24	28	28	38	38
by	3	4	5	6	8	8	8	10	10
ty	10.4	12.8	16.3	21.8	27.3	31.3	31.3	41.3*	41.3*



1.9 Braccio di reazione

1.9 Torque arm

1.9 Drehmomentstütze

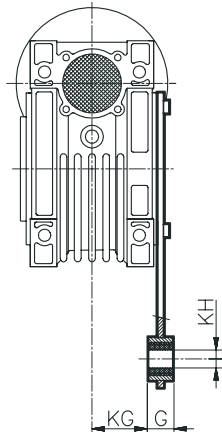
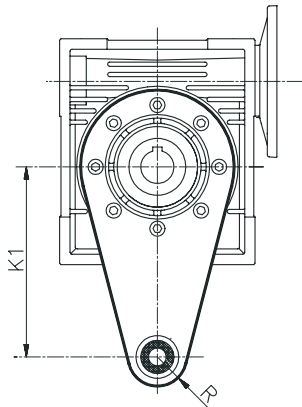

WI - WMI	K1	G	KG	KH	R
25	70	14	17.5	8	15
30	85	14	24	8	15
40	100	14	31.5	10	18
50	100	14	38.5	10	18
63	150	14	49	10	18
75	200	25	47.5	20	30
90	200	25	57.5	20	30
110	250	30	62	25	35
130	250	30	69	25	35
150	250	30	84	25	35

1.10 Alberi lenti

1.10 Low speed shafts

1.10 Abtriebswellen

Albero lento
Single output shaft
Einseitige Abtriebswelle

Albero lento bisporgente
Double output shaft
Beidseitige Abtriebswelle

DZ

SZ

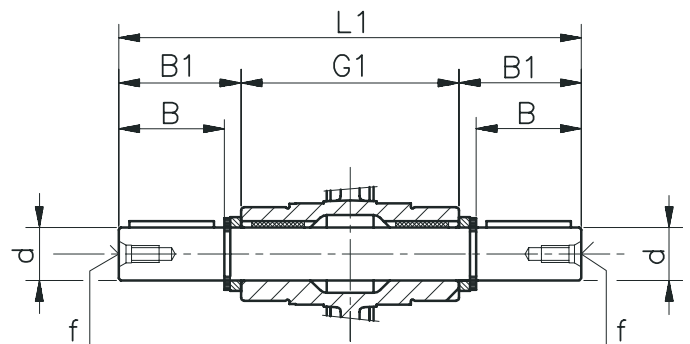
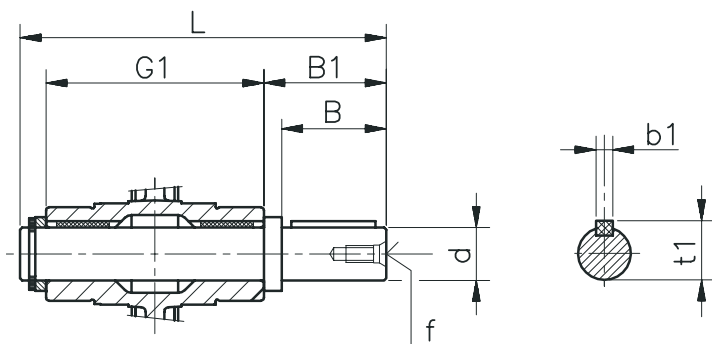

WI WMI	d h6	B	B1	G1	L	L1	f	b1	t1
25	11	23	25.5	50	81	101	-	4	12.5
30	14	30	32.5	63	102	128	M6	5	16
40	18	40	43	78	128	164	M6	6	20.5
50	25	50	53.5	92	153	199	M10	8	28
63	25	50	53.5	112	173	219	M10	8	28
75	28	60	63.5	120	192	247	M10	8	31
90	35	80	84.5	140	234	309	M12	10	38
110	42	80	84.5	155	249	324	M16	12	45
130	45	80	85	170	265	340	M16	14	48.5
150	50	82	87	200	297	374	M16	14	53.5



1.11 Cappellotto

1.11 Cover

1.11 Deckel

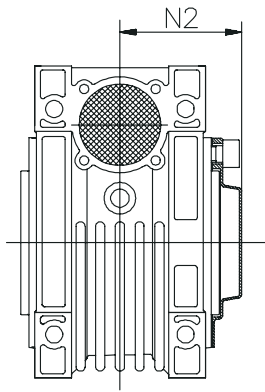

	N2
30	42
40	50
50	57.5
63	68.5
75	73.5
90	85.5
110	94
130	102
150	117